

#2 QQ CUTTER HEAD (STAND ALONE ASSY.)

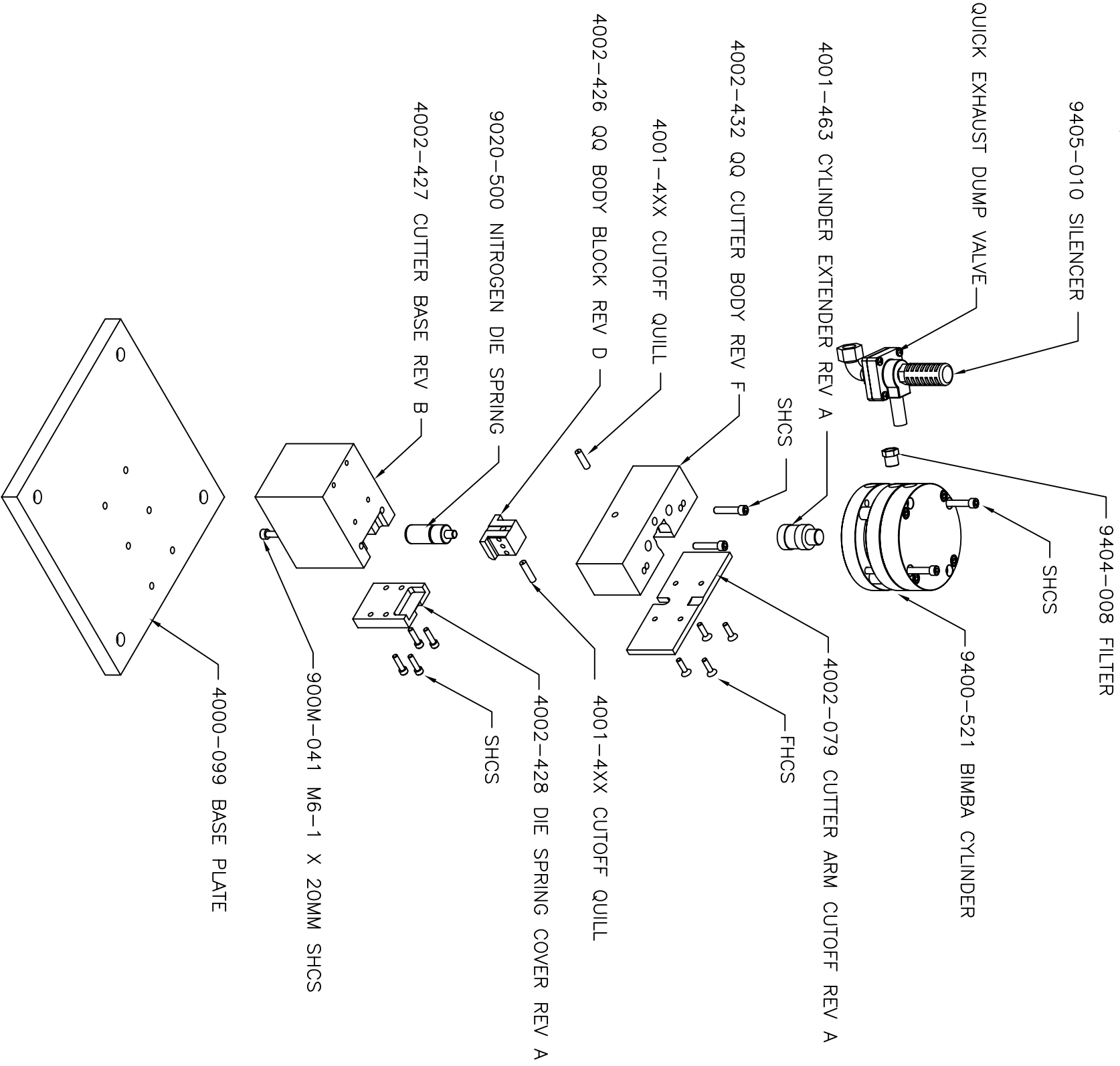
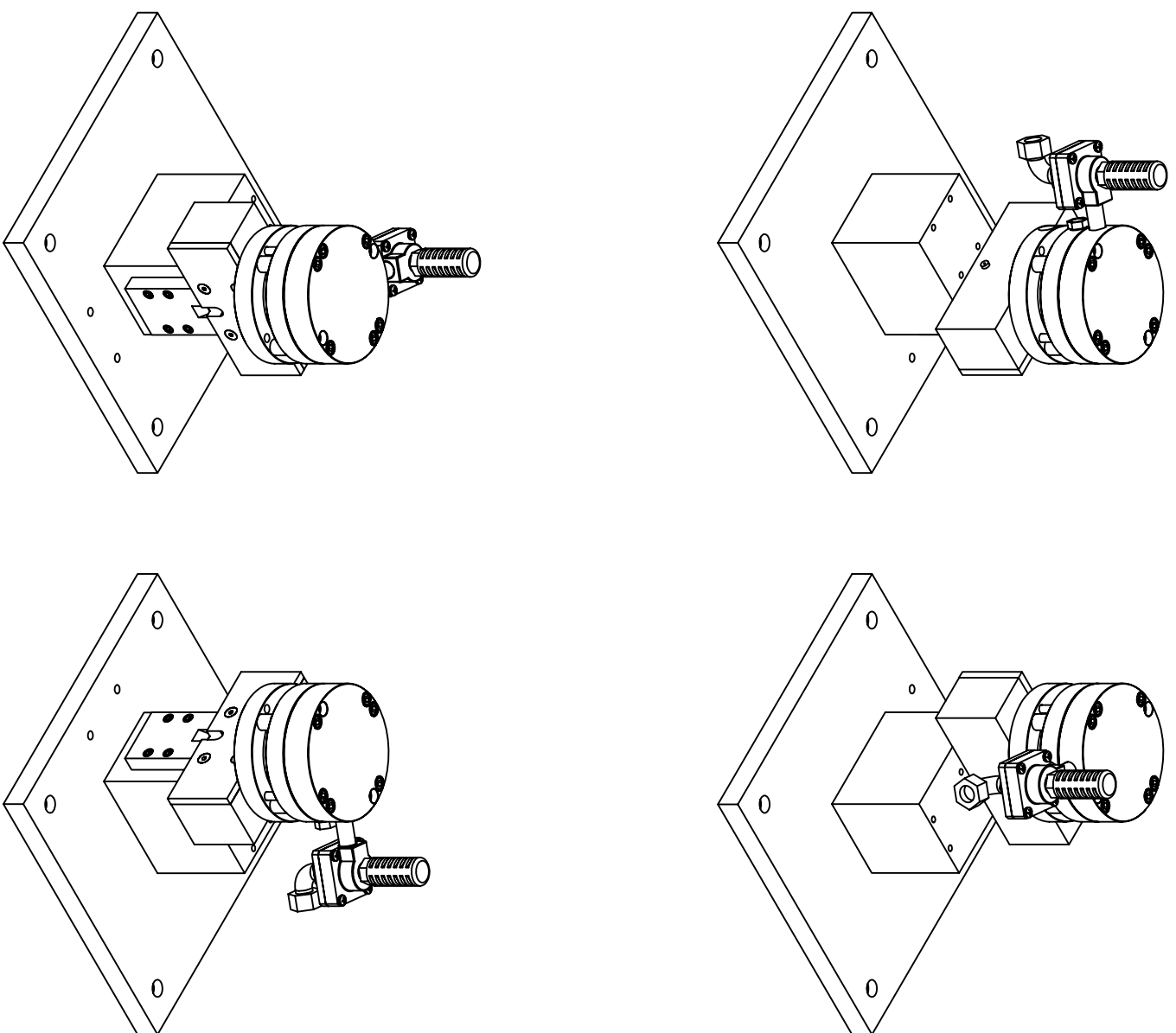

MATERIAL REQ'D.

R.C.

REV	ECN	CHG BY	DATE

DRAWING / PART NO.		PART NAME	
4002-25AH		STAND ALONE	
CUSTOMER		#2 QQ CUTTER HEAD	



TOLERANCE UNLESS OTHERWISE STATED		CAD	
± .3	FRACT +/- 1/16	DWN	KPL
± 0.0003	X	CHK	SCALE
± 0.0002	XX	DATE	1/20/03
± 0.0005	XXX		
± 0.0005	XXXX		